

MODELO

Ballistic





- **Precinto de alta seguridad ISO 17712:2013.**
- Perno de acero al carbono galvanizado, forrado con ABS resistente a altos impactos.
- Cumple con certificación ISO 17712:2013 y C-TPAT .
- Mayor resistencia a la tracción >1500 Kg-f.
- Sistema Anti-giro y bloqueo exagonal.
- Precinto certificado cumpliendo normas de **ADUANA PERU**

Impresión personalizada



Láser Nombre Numeración Bar Code

Aplicaciones



Camiones Transporte concentrado Vagones Containers Variedad de aplicaciones

Medidas (mm)

Modelo
Ballistics
Longitud

87 mm

Diametro de perno

8 mm

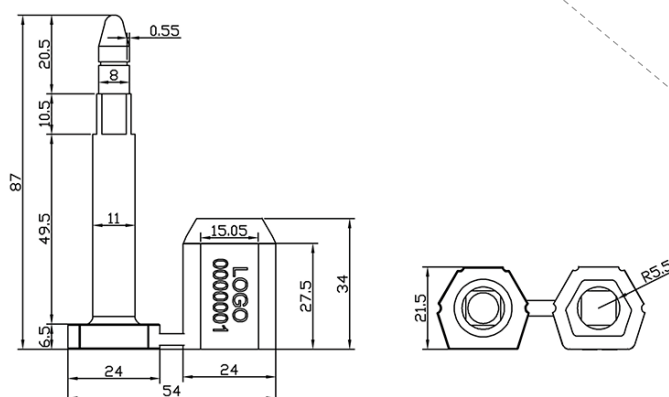
Mecanismo de bloqueo
Hexagonal

Productos Certificados:
